



Smart Sewage Solutions Pty Ltd

Owner's Guide

P O Box 3006
West Ipswich QLD 4305

Telephone: **5460 9111**

Facsimile: 5460 9110

E-mail: smartsewagesolutions@bigpond.com

Krystel Kleer

Secondary Treatment with your choice of
Chlorine or UV Disinfection

Wastewater Treatment System

CD100

For up to 10 persons



CD6000

For up to 15 persons

**Phosphate &
Nutrient Reducing**

Effluent & Wastewater Recycling



Owner's Guide

www.smartsewagesolutions.com.au

Service Provider Details

Your **Krystel Kleer** treatment system's complimentary first year maintenance program is provided by the following company:

Krystel Kleer (Quality Tanks)
P O Box 5168
Gold Coast MC QLD 9726

Telephone: (07) 3382 7666
Facsimile: (07) 3382 6411

Please remember to notify them if you sell your property!

*This handbook has been produced to assist your understanding of the **Krystel Kleer**.
Please keep it in a safe place for easy reference.
If you have any questions, contact your service provider.*

Contents

	<i>Page</i>
1 The Krystel Kleer Process Flow	1
2 Maintenance of your Krystel Kleer	2
Maintenance programme	2
Renewal	2
Home Owner Requirements	3
Access	3
Housekeeping	3
Air blower damage	3
Run-off	4
De-sludging	4
Within the house	4
3 The Irrigation Disposal Area	5
Volume of water	5
Help protect your health and the environment	5
Some suitable plants	6
4 Handy Hints	7

Contents

	<i>Page</i>
5 Cleaning Products	9
In general	10
6 Fault Finding	11
Alarm sounding	11
Irrigation not spraying	11
Excessive foaming	11
Plumbing problems	11
Persistent odour	12
Circuit breaker	13
7 Warranties	14
8 Electrical Circuit Specifications	15
Supplied for INFORMATION ONLY.	

1 The Krystel Klear Process Flow

The *Krystel Klear* method for the treatment of sewage and sullage from your home is based on the age-old principle of separating the solids from the liquids, allowing anaerobic bacteria (they do not require oxygen to be present) and aerobic bacteria (they do require oxygen) to digest the waste.

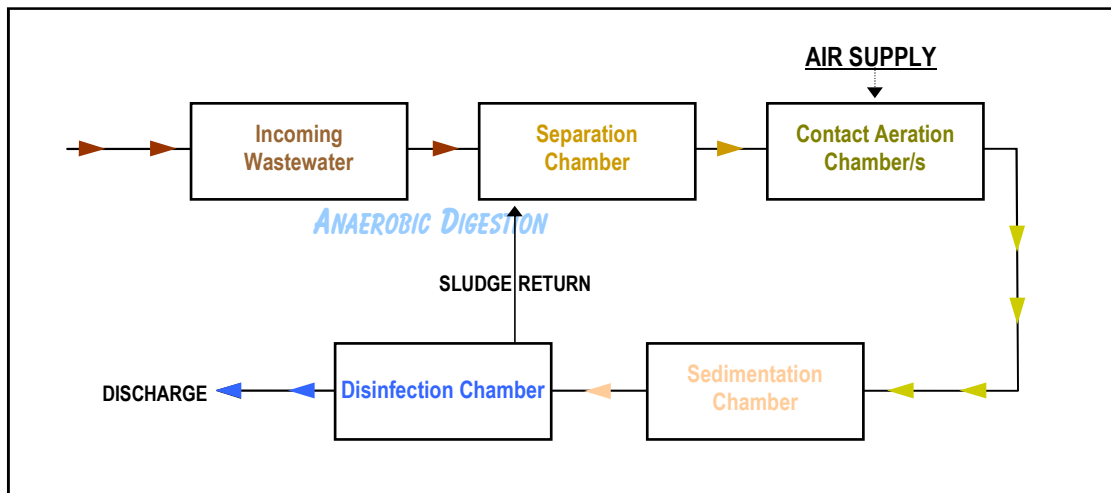

Primary Treatment

The first stage of treatment is to separate the solids from the liquids. The solids (mainly toilet wastes) remain in the first compartment where a digestion process takes place. The digestion is accelerated by the presence of anaerobic micro-organisms that multiply rapidly under ideal conditions and ensure that the offensive faecal solids are turned into an inert waste.

Secondary Treatment

Aeration

The subsequent treatment stages are mainly concerned with the aeration of the liquid wastes. Once again, microbes present in these liquids are used to assist in the aeration process. The micro-organisms are called aerobes and will thrive and multiply in the presence of oxygen, so it is important that a constant air supply is being maintained at all times. The air is supplied from an air pump attached to the system.

Clarification

Following aeration, the liquid wastes are allowed to settle under quiescent conditions. Any solid particles suspended in the aerated effluent will settle out and are returned automatically to the first or second treatment stage. Although it looks reasonably clean, the clarified water may still contain pathogens which will have to be removed.

Further Secondary Treatment

Disinfection

The bacteria are removed by either *ultra-violet or chlorine* while in the disinfection chamber, ensuring *complete disinfection*.

Nutrient Removal

The aerated, clarified and disinfected water contains natural nutrients such as phosphates and nitrates, which can pose a problem in certain conditions. The *Krystel Klear* reduces the nutrient concentration, limiting potential damage to the surrounding landscape and waterways.

2 Maintenance of your Krystel Kleer

All sewage treatment systems require regular maintenance to ensure that the effluent quality consistently meets the standards set by the regulating authority. To ensure that your **Krystel Kleer** sewage treatment plant performs to the highest standards, a maintenance program is stipulated by your local authority in the interests of environmental health and safety. Failure to have these stipulated services carried out could result in a breach of public health legislation and subsequent legal proceedings.

Once your **Krystel Kleer** system is installed, you are assured of total peace of mind. The **Krystel Kleer CD Series** has been approved for **quarterly servicing**. **Krystel Kleer** technicians will check, service and maintain your system under your complimentary first year service contract, and emergency after-hours attendances are simply a telephone call away.

Apart from general maintenance, various water quality tests are conducted onsite and inspection records are kept. Reports are sent to regulating bodies in order to comply with their conditions of approval.

Maintenance Programme

The following information covering the requirements and maintenance for the first, second and subsequent years of operation is provided for your guidance. At each service, your **Krystel Kleer** technician will:

- make any necessary adjustments to the air intake
- make any necessary adjustments to the sludge return
- clean the plant (if necessary)
- test and replenish the purifiers
- check and report on sludge levels
- clean the UV disinfecting light (if applicable)
- perform onsite tests of water quality
- report to your local council and yourself as directed
- complete a service and maintenance check of the blower, irrigation pump, UV light (if applicable) and electrical systems, including the alarms



Maintenance Agreement Renewal

An offer to renew the maintenance program will be provided at the expiration of each annual contract and will remain open for 30 days only. Current legislation requires that all treatment plant service providers notify the local council of any contracts that have not been renewed at the expiration of those 30 days.

2 ... Maintenance of your Krystel Kleer

Home Owner Requirements

The owner of the plant (you) will be licensed by your local Council and will be entirely responsible for the operation and maintenance of the plant. The existence of a service contract does not transfer the responsibility from the owner to the supplier or service provider.

Our exclusive handover and **owner's guide** are valuable tools in your operational training. It's not rocket science, but you might find that a little bit of training and advice in the early days could be very beneficial.

- Ensure the warning signs are clearly visible by maintaining your land application area free from weeds and debris.
- Regular visual checking of your *Krystel Kleer* system's exterior and irrigation system will ensure that most problems are located and fixed early.
- The visual signs of the land application system failure include:
 - surface ponding or run-off of treated wastewater
 - soil quality deterioration
 - poor vegetation growth
 - unusual odours



See Section 3 The Irrigation Disposal Area (page 5) for more information.

Access

For maintenance purposes, FREE access is required to ALL manholes on the tank and to the ELECTRIC BOX. This is a requirement of the regulating authority.

Housekeeping

Over time the system's irrigation lines, spray heads etc can clog up with dirt, pebbles etc. Manufacturers of such equipment recommend that these items be flushed at least monthly.

To avoid any inconvenience to you, and to help keep your costs down, we strongly urge you to comply with these recommendations.

Air Blower Damage

Avoid this very costly problem! Create channels to take rainwater away from the vicinity of the electric box. Insurance companies will not reimburse you for blower damage caused by your negligence.

2 ... Maintenance of your Krystel Kleer

Run-off

Currently legislation states that generally speaking, everything produced on the property must be contained within the property, including treated effluent, stormwater, run-off, smells, odours etc.

You are not permitted to water the Council's footpath and care should be taken not to allow any run-off onto your neighbour's land.

Please leave diversion/retention mounds in place.



De-Sludging

All treatment plants accumulate sludge, despite advertising material to the contrary by some other companies. Sludge is the matter going down the drains that is not organic, for instance sand from the beach brought home in swimming apparel, towels, clothes etc.

Dependent on individual household usage, it will be necessary to periodically remove the contents of the septic tank/compartments. Your service technician will advise you when de-sludging is required, but it is your (the licence holder's) responsibility to organise the service.

De-sludging may be carried out by any person or organisation approved by the Health Department. Australian Standard AS/NZS 1546.1 recommends de-sludging at intervals of 3-5 years for optimum performance.

Within the house

- Reduce foaming by adding a tablespoon of crushed bath soap (leftovers) to your washing powder.
 - After wiping down tiles and the like, rinse the cloth in a bucket then discard the contents in the yard, not the system.
 - When the alarm sounds, PLEASE refer to the fault finding section of this guide before calling your service provider
-

3 The Irrigation Disposal Area

The irrigation disposal area will have been approved and inspected by either or both an officer from the council and the Geotechnical Engineer following the commissioning of your *Krystel Kleer* for use.

At each quarterly service visit your service technician will inspect the irrigation area, and a report of its condition will be made to your Council.

Remember—the area's upkeep and maintenance are your responsibility.

Volume of water

Land application areas and systems for onsite application are designed and constructed in anticipation of the volume of waste to be discharged. Uncontrolled use of water may lead to poorly treated effluent being released from the system.

If the land application area is waterlogged and soggy, the following are possible causes:

- overloading your treatment system with excessive wastewater
- your land application area has been poorly designed
- stormwater is running onto the area

See Section 4 Handy Hints (page 7) for suggestions.

Help protect your health and our precious environment . . .

Poorly maintained land application areas are a serious source of water pollution and may present health risks, cause odours and attract vermin and insects.

The Krystel Kleer CD Series is best for your health and the environment!



By looking after your sewage management system, you can do your part in helping to protect the environment and the health of you and your family.

3 ... The Irrigation Disposal Area

This list is only intended to provide a selection of trees, shrubs and other plants that **may be** considered suitable for your treatment system's surface irrigation disposal area.

Botanical Name	Common Name
Climbers	
<i>Bougainvillea spp.</i>	
<i>Hardenbergia violacea</i>	Purple Coral Pea
<i>Hibbertia scandens</i>	Snake Vine
<i>Jasminum officinate</i>	Common Jasmine
<i>Jasminum Grandiflorum</i>	
<i>Kennedia rubicunda</i>	Dusky Coral Pea
<i>Lonicera japonica</i>	Japanese Honeysuckle
<i>Passiflora spp.</i>	
<i>Vitis coignetiae</i>	Glory Vine
<i>Pandorea jasminoides</i>	

Due to the wide-ranging climate and soil variations we experience in Queensland, we strongly recommend that you make further enquiries with your local plant nursery before finalising your plant choice.

Botanical Name	Common Name
Perennials	
<i>Aster novi-beigii</i>	Perennial Aster
<i>Canna</i>	
<i>Chrysanthemum frutescens</i>	Marguerite Daisy
<i>Chrysanthemum maximum</i>	Shasta Daisy
<i>Gazania rigens</i>	Black-eyed Susan
<i>Salvia uliginosa</i>	Bog Salvia

Botanical Name	Common Name	Approx Height
Trees		
<i>Agonis flexuosa</i>	Willow Myrtle	5-6m
<i>Acacia baileyana</i>	Cootamundra Wattle	3-6m
<i>Banksia spp.</i>		
<i>Casuarina glauca</i>	Swamp Oak	6-12m
<i>Casuarina stricta</i>	Drooping Sheoake	3-5m
<i>Casuarina cunninghamiana</i>	River Sheoake	6-10m
<i>Callistemon viminalis</i>	Red Bottlebrush	3-6m
<i>Callistemon salignus</i>	White Bottlebrush	3-6m
<i>Eucalyptus grandis</i>	Flooded Gum	10-15m
<i>Eucalyptus camaldulensis</i>	River Red Gum	15-20m
<i>Eucalyptus cosmophylla</i>	Cup Gum	5-6m
<i>Hakea spp.</i>		
<i>Hymenosporum flavem</i>	Native Frangipani	3-6m
<i>Leptosporum laevigatum</i>	Coast Tea Tree	5-6m
<i>Melaleuca armillaris</i>	Bracelet Honey Myrtle	3-4m
<i>Melaleuca quinquerivaria</i>	Broad Paperbark	5-7m
<i>Melaleuca nesphila</i>	Western Tea Myrtle	2-4m
<i>Syzygium paniculatum</i>	Bush Cherry	8-10m
<i>Tristania laurina</i>	Kanuka	3-5m

Botanical Name	Common Name	Approx Height
Shrubs		
<i>Abelia x grandiflow</i>	Abelia	-23m
<i>Acacia floribunda</i>	Gossamer Wattle	2-4m
<i>Acacia longifolia</i>	Sallow Wattle	2-4m
<i>Acacia iteaphylla</i>		
<i>Alocasia Purpurea</i>		
<i>Chamaelucium uncinatum</i>	Geraldton Wax	2-4m
<i>Clerodendrum heterphylla</i>		
<i>Cotoneaster spp.</i>		
<i>Cortaderia selloana</i>	Pampas Grass	2-3m
<i>Cupha ignea</i>		
<i>Cuphea micropetala</i>		
<i>Cyperus alternifolius</i>	Umbrella Grass	0.5-1m
<i>Cyperus papyrus</i>	Papyrus	
<i>Hebe spp.</i>	Veronia	0.5-1m
<i>Iris pseudacorus</i>	Yellow Flag Iris	0.5-1m
<i>Melaleuca decussata</i>	Cross Leaf Honey Myrtle	1-2m
<i>Nerium oleander</i>	Oleander	2-3m
<i>Phormium tenax</i>	New Zealand Flax	2-2.5m

4 Handy Hints

To assist you in keeping your treatment system operating to the highest possible standard we at Smart Sewage Solutions provide you with the following hints:

- 
- DO** construct and maintain diversion drains around the top sides of your land application area to divert surface water.
 - DO** ensure that your land application area is kept level by filling any depressions with good quality top soil (**not clay**).
 - DO** keep the grass regularly mowed and plant small trees around the perimeter to aid absorption and transpiration of the treated wastewater.
 - DO** ensure that any stormwater run-off from the roof, driveway and other impermeable surfaces is directed away from your land application area.
 - DO** ensure appropriate Warning signs are visible at all times in the vicinity of a spray irrigation area.
 - DO** visually check your irrigation system regularly to ensure the sprays are operating and free from blockages.
 - DO** use biodegradable cleaning products labelled “septic safe”. Do not use products that contain disinfectants (ie chlorine, bleach) benzene or phosphates. Benzene converts to carbonic acid which is a strong disinfectant.
 - DO** spread your washing loads over the week, eg 1 or 2 loads per day.
 - DO** renew your annual maintenance servicing agreement.
 - DO** contact your service provider if you have any queries or concerns.
 - DO** react immediately if the alarm is activated to eliminate the problem as soon as possible. Refer to the fault finding section on page 11.
-

4 ... Handy Hints

DO NOT erect any structures, construct paths, graze animals or drive over your land application area.

DO NOT plant large trees or shrubs that shade your land application area, as the area needs sunlight to aid in the evaporation and transpiration of the treated wastewater.

DO NOT plant trees or shrubs near or on house drains.

DO NOT allow stormwater lines to discharge into or near your land application area.

DO NOT water fruit and vegetables with the treated wastewater.

DO NOT extract treated wastewater for potable (drinkable) use.

DO NOT flood your land application area through the use of hoses or sprinklers from potable water sources

DO NOT use in-sink garbage disposal units.

DO NOT dispose of foreign objects into the system (eg nappy liners, disposable nappies, sanitary products, condoms, plastic etc). A foreign or man-made object will not break down and may block the system.

DO NOT use strong caustic alkalis, oils, bleaches, disinfectants or chemical detergents. These items kill the purifying bacteria, which will cause odours and damage your system.

DO NOT pour large quantities ($\frac{1}{2}$ litre or more) of beer, wine, milk or fruit juice into the system. This also applies to small amounts of these items every day (eg cereal and milk left-over from breakfast; baby bottles) - do not pour or rinse down the drain.

DO NOT exceed the maximum design load or subject the system to hydraulic shock loads (use of washing machine and shower/emptying bath at the same time).

DO NOT use hair dyes as the peroxide in the dye will kill the bacteria in the system.

DO NOT switch off the power to the system.

5 Cleaning Products

The following list of products that **CAN** be used is not intended to promote or discredit the product or bear reflection upon the manufacturer of the product.

Washing Powders, Liquids and Softeners			
Add Soft	Drive	Love & Care	Softly
Blue Gum	Dynamo	Lux	Somthin' Else
Blue Sno	Ease	More	Spree
Care	Embassy	Omo	Sunlight
Castle	Fab	Omomatic Liquid	Surf
Cold Power	HLD	Parry's	Top Wash
Cuddly	Hurricane	Purlite	Woolmix

Dishwashing Liquids			
Adds	Green Apple	Morning Fresh	Sunlight
Bushland	Kit	Palmolive	Trix
Finish (powder ONLY for dishwashers—not Powerball)			

Cleaners			
Jiff	Spray & Wipe	Swipe	Sugar Soap
Nifty	Shower Power	Windex	

Others			
Epsom Salts			
Lectric Soda Crystals			



With all cleaning—

DO NOT USE AN EXCESS OF CLEANERS OR DETERGENTS

The following list of products that should be **AVOIDED** is not intended to promote or discredit the product or bear reflection upon the manufacturer of the product.

Anti-bacterial Solutions, Bleaches, Cleaners			
Alcohol	Drano	Marvolinn	Flea, Tick, Pet Wash
Ajax	ESP Herbal	Methylated Spirits	Pine-o-clean
Aussa	Exit Mould	Milton Tablets	Preen Soaker
Bio-Ad	Fiesta	NapiSan	Spirits
Bio Joy	Floor Cleaners	Nappy Fresh	Swipol
Blue Loo	Green Choice	Nappy Plus	Toilet Duck
Bubble Baths	Handy Andy	Nappy Soft	Tri-Zyme
Domestos	Kerosene	Nursil	White King
Down to Earth	Lemon Budget	Oven Cleaners	Zixo

In General

Treatment systems rely mainly on bacteria for treatment, therefore any product that you use in the house that kills bacteria and is washed down your drains is going to be harmful to your *Krystal Kleer* to some degree. We say to some degree because the harm is often caused by an accumulative effect. By this we mean regular dosing (small amounts every day), or a variety of contributing chemicals (perhaps over the last week).

Use only gentle, biodegradable products.

If you wish to use some of the harsher cleaning products, do so in a bucket then discard the contents of the bucket into the garden.

If nappies must be soaked, ensure the bucket water does not enter the system.

6 Fault Finding

On rare occasions some minor mishaps, which can generally be easily rectified, do occur.

DO NOT PANIC as the alarm is designed to come on early.

Alarm Sounding

First, turn the alarm to “Mute”.

If your alarm’s **Yellow** light has activated, this indicates a problem with the air blower. Listen at the control box to hear if the blower is running. If you can’t hear it humming, refer to page 13.

If your alarm’s **Red** light has activated, the problem is high water within the system. Check that your irrigation hose isn’t kinked or blocked, and straighten the hose. Check that the irrigation outlets are clear from blockages. Check the inline filter.

NOTE: During periods of heavy rainfall your red alarm may activate. This can be caused through surface water entering the system and filling it faster than your irrigation pump can keep up with.

Ensure your sprinklers are downhill of the system and diversion mounds/cut off drains are maintained and not removed or eroded.

Irrigation not spraying

You may notice the irrigation not spraying before the alarm activates. Check that your irrigation hose is not kinked or blocked, and straighten the hose. Check that the irrigation outlets are clear from blockages. Check the inline filter.

Excessive foaming

Too many washes a day can cause excessive foaming in the system. Limit washes to one or two loads per day. Ensure you use no more than the recommended quantity of washing powder.

Plumbing Problems

BLOCKAGES IN THE DRAINAGE LINES from the house to the system are plumbing problems. If your household fittings are not draining away, please check the inlet to the septic tank or compartment for blockages.

Usually the lines can be cleared at this **INLET** point by inserting a rod down the inlet pipe. Should this not be possible, please call your local plumber or drainer.

THE LOSS OF A WATER SEAL in fittings, allowing gases to escape, should be initially referred to your local plumber for corrective measures.

An incorrectly constructed E Duct Vent could be the cause of this problem.

E DUCT VENTS should be constructed to ensure the proper dispersal of gaseous by-products prevalent in all forms of sewage treatment.

The vent should be positioned at least 600mm above the highest point in the house so that prevailing winds will carry away such gases.

6 ... Fault Finding

Persistent Odour

Typical Causes	Action to Take
The first chamber in the system has not yet matured.	Call your service provider for advice.
Too much water is being discharged through from the house at the same time.	This is called shock loading. Avoid using, for instance, the shower and the washing machine at the same time.
Excessive chemicals and/or disinfectants are being used in the household.	The system will recover once excessive amounts of these products are stopped from entering the system. Call your service provider for advice.
Smell emanating from E-duct vent or S-bends	Sometimes the water evaporates in S-bends and this allows odours from the treatment system to escape back up to the house. Pour a bucket of warm, soapy water (or warm water and washing soda) down your floor drains. Otherwise refer to your plumber or service provider for advice.
Exposed areas in tanks / seal degradation.	Apply a light mix of sand and cement or similar mix.
The system is required to do more than it is designed for.	Refrain from overloading. Call your service provider for advice.

6. ... Fault Finding

Circuit Breaker

The use of proven high quality materials ensures long life of your *Krystal Kleer*. You will appreciate however that we have no control over the power supply to your home.

Although the circuitry allows for variances in power supply, a power cut, substantial surge in power or voltage drop in your area may trip the circuit breakers and trigger the early warning system supplied.

You may live in an area that is prone to fluctuating power supplies. On rare occasions this may cause your *Krystal Kleer* system to shut down, resulting in the alarm operating.

The fluctuating power supply may cause the overload circuit breaker in your switchboard to trip to the “off” position (down position). This is not a fault of the system but rather it is a characteristic to protect the equipment within the system.

If, after a power cut or voltage fluctuation the *Krystal Kleer* system alarm does not clear itself within 12 hours, it may be necessary for you to reset the tripped circuit breaker:

Open your switchboard and look for the circuit breaker marked “Krystal Kleer” or similar. There will be **two** circuit breakers. If one of them is in the **down** position, it is **off**. To re-set, lift the circuit breaker toggle to the **up** position. Upon doing this, the blower will immediately re-start and the system will function normally.

The alarm may take up to 12 hours to clear.

Don't forget to re-set the alarm to **NORMAL**

***IF THE CIRCUIT BREAKER SWITCH WILL NOT STAY UP,
CALL YOUR SERVICE PROVIDER IMMEDIATELY.***

Remember: This problem is beyond our control

Note: For security reasons we suggest that when on holidays you turn the alarm to **MUTE**. Upon your return, revert the alarm back to the **ON** position.

7 Warranties

Structure	Warranty	Minimum Service Life
Concrete Tank	15 years	20 years
Internal Baffles (concrete)	15 years	20 years
Fittings		
Pipework (PVC etc)	15 years	20 years
Fixing (Stainless etc)	15 years	20 years
Filter Media	15 years	20 years
Electrical Components		
Control Box	2 years *	5 years
Alarm Panel	2 years *	5 years
Irrigation Pump	2 years *	5 years
Aeration Pump	2 years *	5 years
UV Disinfecting Light (if applicable)	2 years *	5 years

Warranties

* 12 month standard warranty and a 12 month extended warranty if you renew your first year maintenance agreement with a Krystel Kleer approved service provider.

The warranty covering the aeration pump begins when the system is commissioned for use or the pump is delivered, whichever occurs first.

All other warranties covering the treatment system begin on the date the system is delivered to your property.

Service life

All mechanical and electrical parts have a minimum service life of 5 years.

“Service life” is the time for mechanical and electrical parts to operate before breakdown or failure can reasonably be expected.

8 Electrical Circuit Specifications—For Information ONLY

Attention Home Owner: This page is supplied for **your information only**.

All electrical work carried out on the system and the power supply **must be carried out by a licensed electrician**.

Important—Conduit Sealing

The conduit must be run to the junction box mounted in the side of the control box on the treatment tank. **Ensure that you glue all the joints in the conduit run** to prevent moisture from entering the Krystel Kleer control box via your conduit and causing damage. **Moisture ingress is not covered by the manufacturer's guarantee.**

Circuit

A dedicated single phase plus earth circuit is to be used, protected by a 16 amp MINIMUM circuit breaker of 8Ka type suitable for motor start (such as Weber/Martec AS168 type, Quicklage, Teresaki Safe "T" or Clipsal "U" type), minimum cable size 215mm, connected to and run from an EXTERNAL building switchboard (to allow for maintenance when the house is unattended) to the Krystel Kleer terminal box. Alarm wiring run can be two-core switch wire.

Circuit should be labelled "Krystel Kleer System" and must be connected to the terminals as labelled in the **Krystel Kleer** terminal box.

Current/Amps

Continuous running current is 0.6amp with maximum intermittent current up to 3.1 amps (dependent upon submersible pump size).

Alarm

The alarm may sound upon initial energising of the circuit to the system. This may be caused by a high water level and is no cause for concern. If the power is left on, the water level will return to normal within 30 minutes and the alarm will automatically reset. Be sure to return the alarm to "NORMAL" after the alarm has reset.

Alarm Panel

If the alarm panel is more than 30 meters away from the Krystel Kleer control box, use shielded cable for **SW to alarm panel** to avoid any induced voltage from active cable.

Fault Conditions: **Yellow** light and buzzer = low air pressure

Red light and buzzer = high water

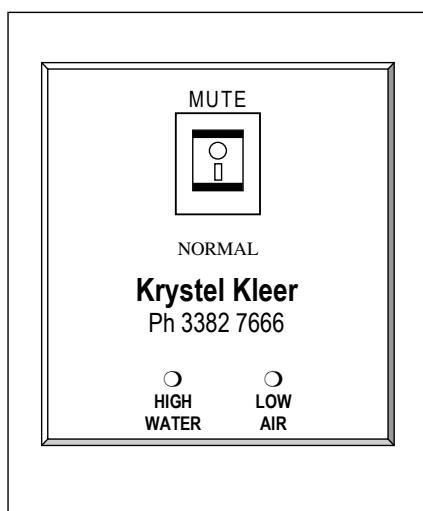

ALARM PANEL

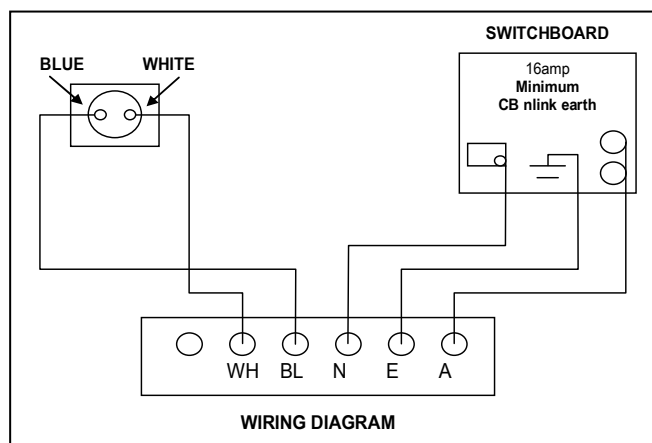

WIRING DIAGRAM

Package Specialists

PROUDLY UTILISING INNOVATIVE PRODUCTS
AND SERVICES, INCLUDING:

Krystel Kleer
Wastewater Treatment Systems



Duraplas



QUALITY TANKS
CONCRETE RAINWATER TANKS



Contact us for a competitive price!

- **Domestic sewage treatment plants** We are experts within our industry and local council areas
- **Concrete pre-cast water tanks** 5000/ to 45,460/
- **Polyethylene tanks** Our range includes slimline, tower and cylindrical (round)
- **Water pumps** Jet-assisted household pressure; constant pressure; submersible; multi-stage automatic
- **Effluent polishing units** Some councils require this attachment on all treatment systems

Telephone (07) 5460 9111